

AMTECH Developments Ltd

Top Tray Applicator

- For A New Cost Effective Packing Format •



- Developed in conjunction with overseas producers to meet the demand of a growing global market.
- Top tray applicator packs up to 600 bottles per minute.
- Collates bottles into 3 x 2 pack format applying collation top tray around bottle neck giving a cost effective multi-pack product format.
- Unit can be supplied as Twin Lane (as shown above) or Single Lane (model 300/1) which will pack up to 300 bottles per minute.

practical • cost effective • efficient

Engineering Solutions for the Food & Dairy Industry



Scroll Drive Unit

Main Control Panel

Tray Loading Magazines

Product Infeed Accumulation Conveyor

Optional Hand Packing Table
(Option to feed directly into an Auto Palletiser)

Tray Loading Platform

AMTECH
DEVELOPMENTS LTD

AMTECH DEVELOPMENTS
Top Tray Applicator
Model 600/2

Plan:

Hand Packing Station

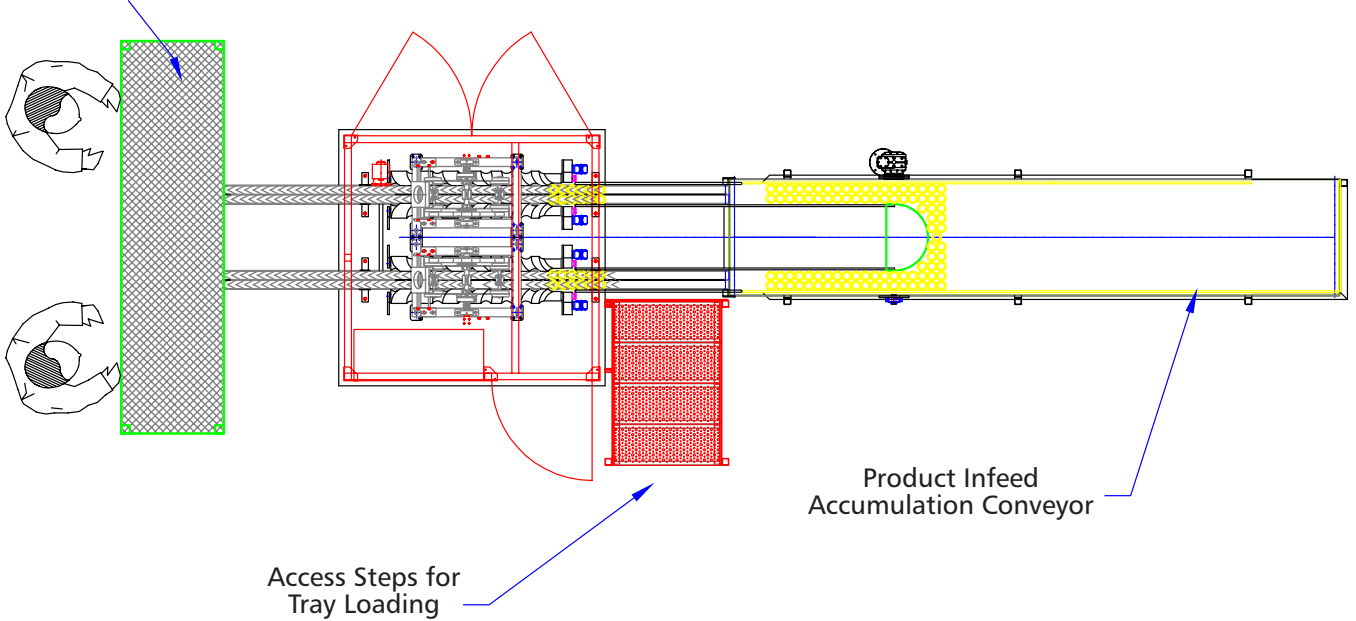

© Amtech Developments 2008

The Top Tray Applicator

- ✓ will pack any number of other x2 formats, such as 2x2 4x2 5x2.
- ✓ is suitable for different bottle sizes and profiles.
- ✓ requires minimal operator input.
- ✓ has a power consumption of less than 2.5kw giving significantly lower running costs than alternatives such as shrink wrapping.

AMTECH DEVELOPMENTS LTD

Unit 9, Firmin Coates Industrial Estate, Middlewich Road, Byley, Cheshire CW10 9NT, United Kingdom

Contact Us:

Telephone

from outside the UK: +44 1606 841114

from the UK: 01606 841114

Email sales@amtechdev.com

Web www.amtechdev.com